

INSTRUCTION SHEET FOR WALDEN PICNIC TABLE WITH 3X4 WOOD OR RP

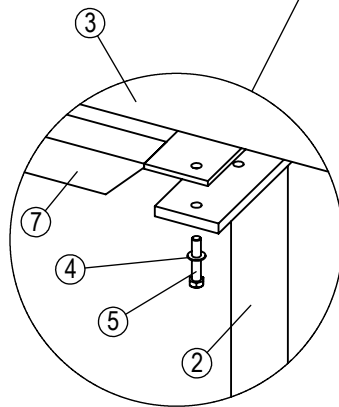
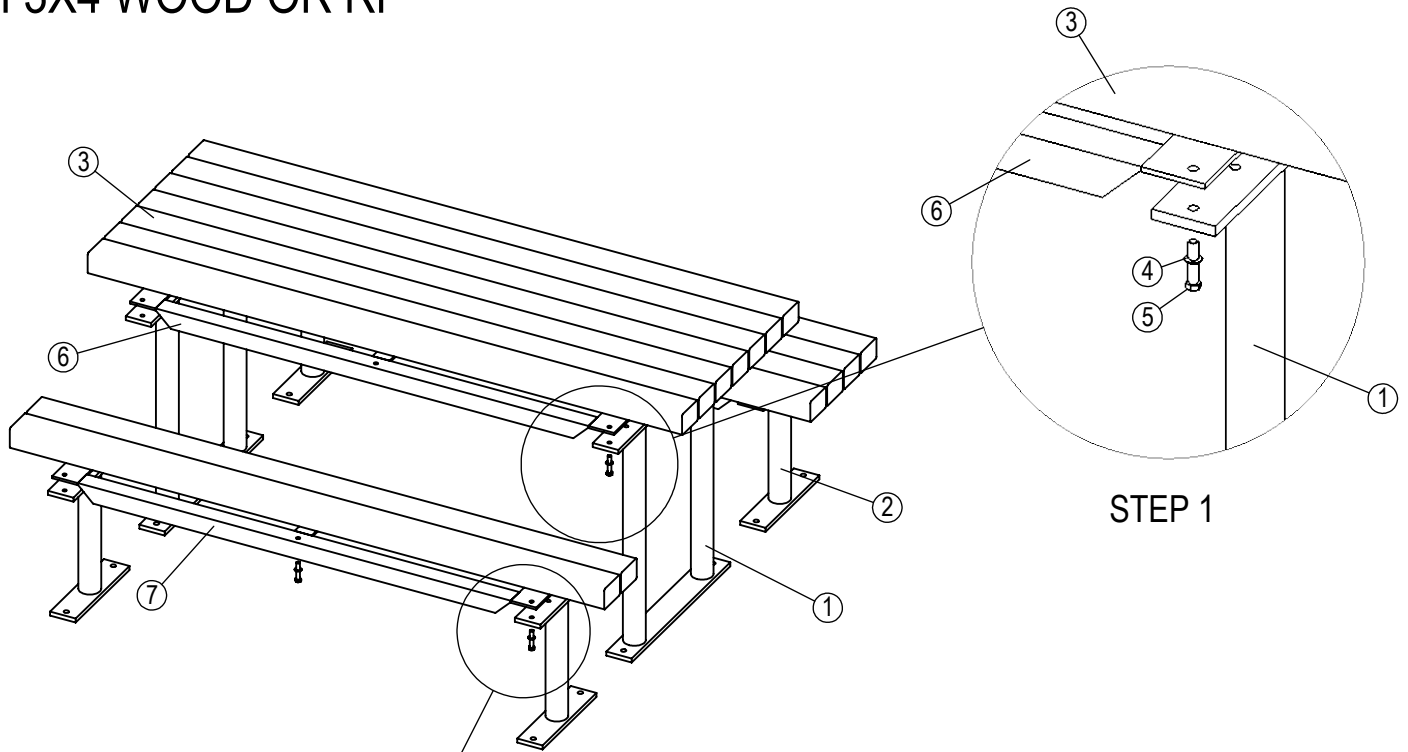

STEP 1 ASSEMBLE 3 X 4 PROFILES TO TABLE TOP FRAME OR TABLE TIE AND TABLE LEGS WITH WASHERS AND LAG BOLTS.

STEP 2 ASSEMBLE 3 X 4 PROFILES TO SEAT FRAME OR SEAT TIE AND SEAT LEGS WITH WASHERS AND LAG BOLTS. REPEAT FOR OTHER SEAT ASSEMBLY.

ITEM #	QTY	DESCRIPTION
1	2	TABLE LEGS
2	4	SEAT LEGS
3	16	3 X 4 PROFILES
4	48	3/8" SS WASHER
5	48	3/8" SS LAG SCREW (2" FOR RECYCLED PLASTIC, 1 1/2" FOR WOOD)
6	1	TABLE TOP FRAME (RECYCLED PLASTIC ONLY)
7	2	SEAT FRAME (RECYCLED PLASTIC ONLY)
8	1	TABLE TIE (WOOD ONLY)
9	2	SEAT TIE (WOOD ONLY)

RECYCLED PLASTIC TABLE OPTION SHOWN

CONFIDENTIAL DRAWING AND INFORMATION IS NOT TO BE COPIED OR DISCLOSED TO OTHERS WITHOUT THE CONSENT OF GRABER MANUFACTURING, INC. SPECIFICATIONS ARE SUBJECT TO CHANGE WITHOUT NOTICE.

SITE FURNISHING IS POWDER COATED WITH TGIC POLYESTER. STEEL SURFACE PREP INCLUDES MECHANICAL AND CHEMICAL ETCHING FOLLOWED WITH A COATING TO IMPROVE ADHESION AND CORROSION RESISTANCE.