

# INSTRUCTION SHEET FOR WALDEN PICNIC TABLE WITH 3X4 WOOD OR RP

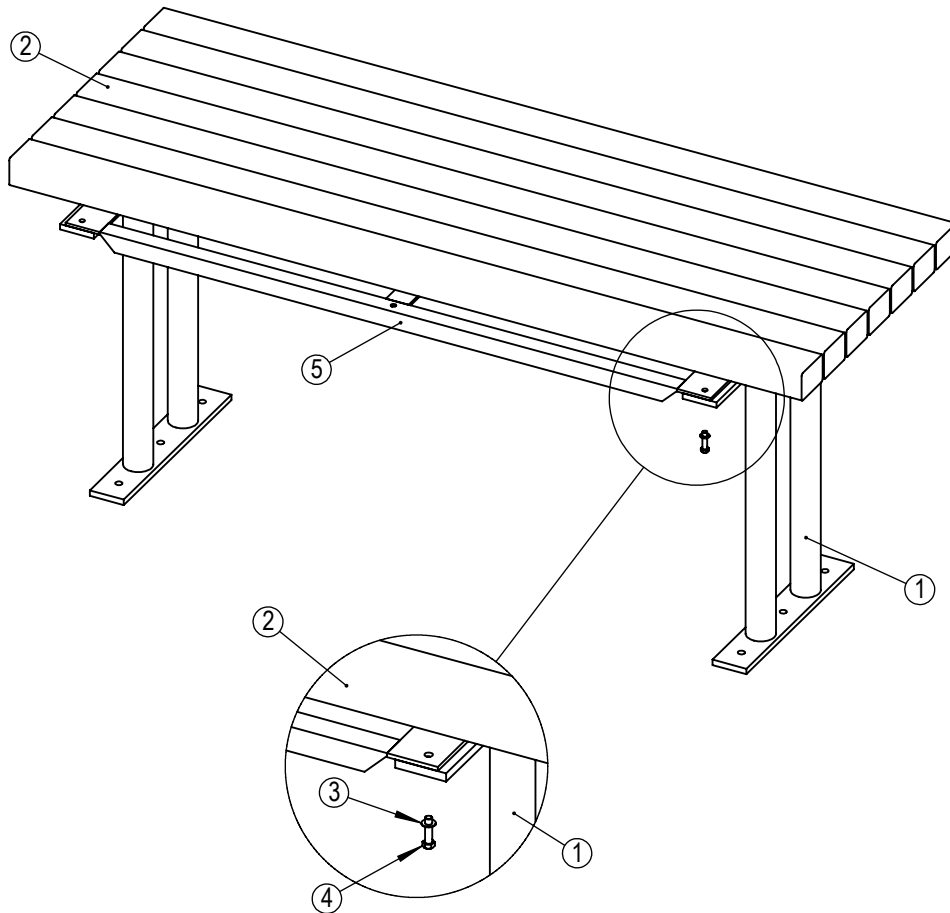

**NOTES:**

ASSEMBLE 3 X 4 PROFILES TO TABLE TOP FRAME AND/OR  
 TABLE TIES AND TABLE LEGS WITH WASHERS AND LAG BOLTS.

ITEM #	QTY	DESCRIPTION
1	2	TABLE LEGS
2	8	3 X 4 PROFILES
3	24	3/8" SS WASHER
4	24	3/8" SS LAG SCREW (2" FOR RECYCLED PLASTIC, 1 1/2" FOR WOOD)
5	1	TABLE TOP FRAME (RECYCLED PLASTIC ONLY)
6	-	TABLE TIE (2 FOR RECYCLED PLASTIC, 3 FOR WOOD)

RECYCLED PLASTIC OPTION SHOWN

CONFIDENTIAL DRAWING AND INFORMATION IS NOT TO BE COPIED OR DISCLOSED TO OTHERS WITHOUT THE CONSENT OF GRABER MANUFACTURING, INC. SPECIFICATIONS ARE SUBJECT TO CHANGE WITHOUT NOTICE.

SITE FURNISHING IS POWDER COATED WITH TGIC POLYESTER. STEEL SURFACE PREP INCLUDES MECHANICAL AND CHEMICAL ETCHING FOLLOWED WITH A COATING TO IMPROVE ADHESION AND CORROSION RESISTANCE.