

WINGRA 6' BACKED BENCH INSTRUCTION SHEET

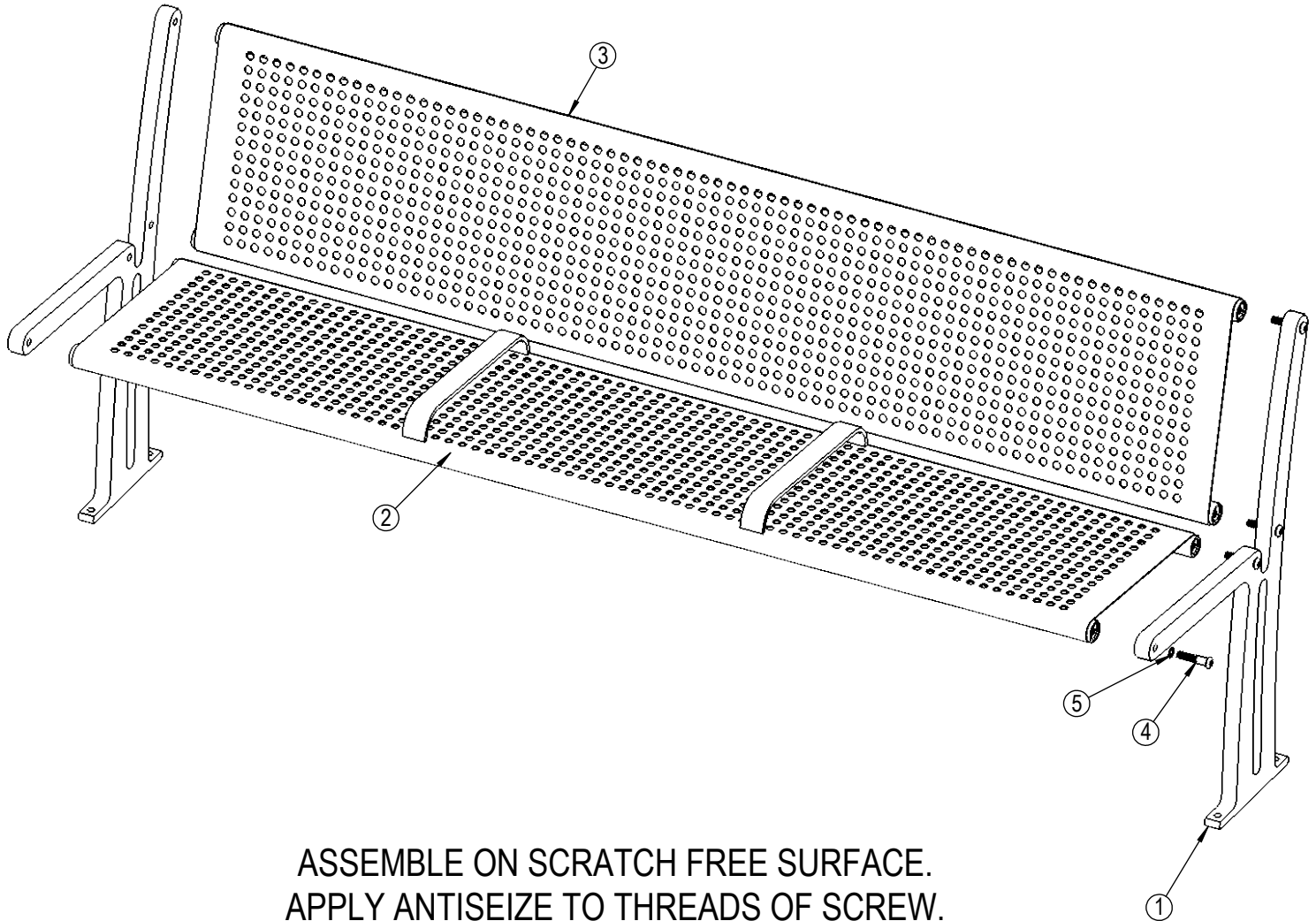

ASSEMBLE ON SCRATCH FREE SURFACE.
APPLY ANTISEIZE TO THREADS OF SCREW.

ITEM NO.	PART NUMBER	QTY.
1	WINGRA END FRAME	2
2	WINGRA-SEAT-6-PM	1
3	WINGRA-SEAT-6-PM WITH OPTIONAL DIVIDER	1
4	2" SS BUTTON HEAD SOCKET CAP SCREW	8
5	Washer 3/8" x .625"OD SS	8
6	ANTISEIZE	1

PERFORATED SEAT SHOWN